

LEO 15 GT TECHNICAL DATA SHEET



SPECIFICATIONS	LEO 15 GT
Working Height	approx. 14.90 m
Platform Height	approx. 12.90 m
Lateral Outreach	approx. 6.40 m
Safe load on cage	max. 200 kg
Range of rotation	355 degrees
Size of cage	1.2 x 0.7 x 1.1 m
Length in travelling position with cage	min. 4710 mm
Length in travelling position without cage	min. 3995 mm
Width in travelling position without cage	min. 780 mm
Height in travelling position	max. 1995 mm
Total weight	1920 kg
Loading possibility	2.65m x 3.65 m
Surface load in loading position approx.	approx. 2.16 kN/m ²
Ground load in standard work position	approx. 4.93 N/cm ²
Adjustable width of caterpillar track	780-980 mm
To be jacked up to ground slope: approx.	approx. 14.8 %
Climbing ability (in direction of traffic):	approx. 36 %
Climbing ability (crosswise to direction of traffic):	approx. 17 %

AM ACCESS, UNIT G2, GREAT FENTON BUSINESS PARK, GROVE ROAD, HERON CROSS,
STOKE-ON-TRENT ST4 4LZ.

TEL. 01782 849100 email. amaccess@btconnect.com





AM ACCESS



The
Complete
Access
Package

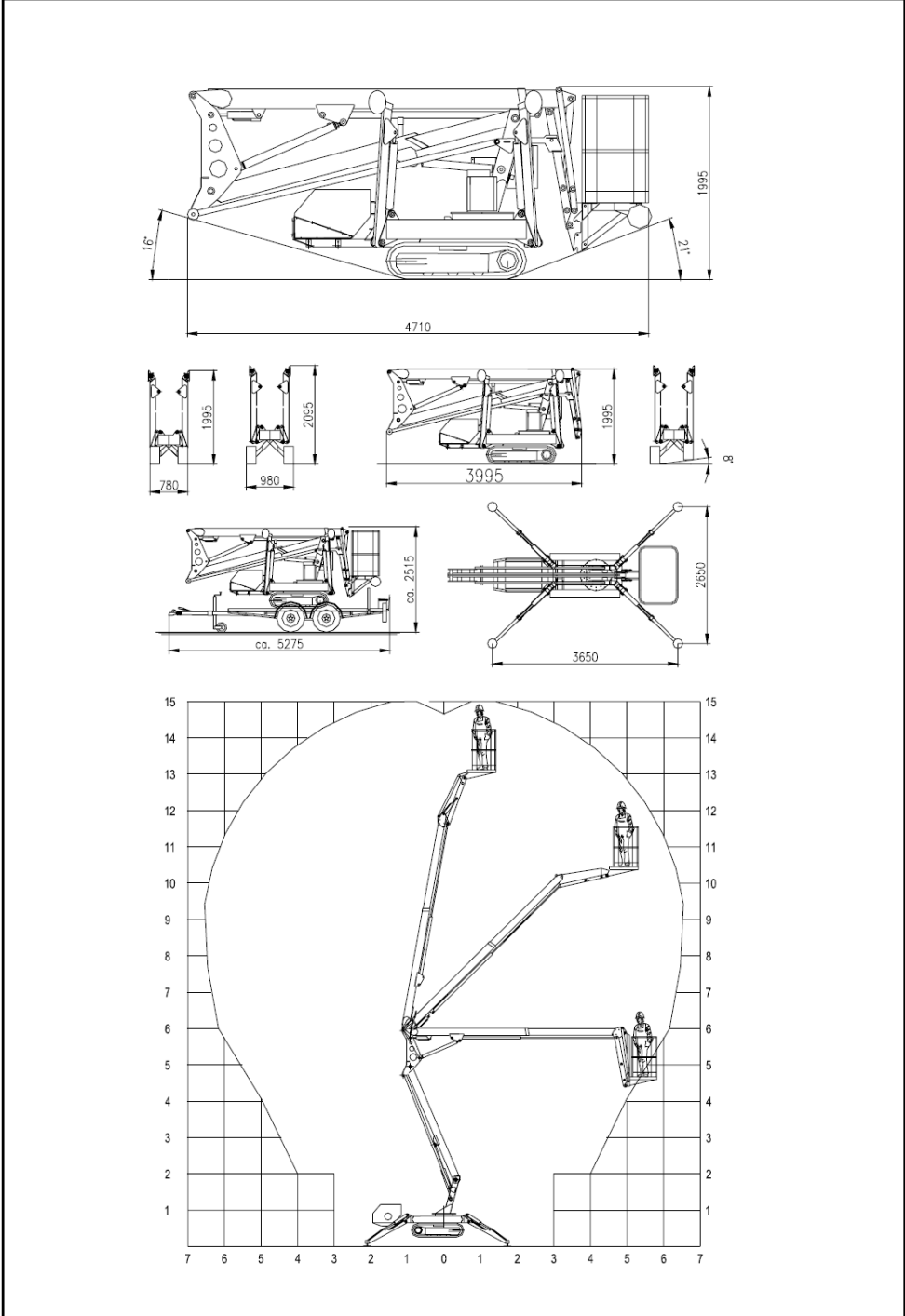

AM ACCESS, UNIT G2, GREAT FENTON BUSINESS PARK, GROVE ROAD, HERON CROSS,
STOKE-ON-TRENT ST4 4LZ.



TEL. 01782 849100 email. amaccess@btconnect.com